

GTQN _ _

CMOS Output

0.6 ps RMS Jitter

SMD

2.5 V

3.3 V

Min.
50 MHz

Max.
250 MHz

Features

Mercury's Low Jitter Differential VCXOs , with a low current consumption (22 mA for CMOS 100 MHz at 3.3V) and an integrated phase jitter performance of 0.6 ps RMS. Gaining its precision frequency control market position by providing engineers with few-day samples for prototypes and low cost, fast delivery for volume production. The perfect solution to replace traditional XO's & VCXO's that use a more expensive, highfrequency, fundamental crystal and a noisy PLL multiplier circuit.

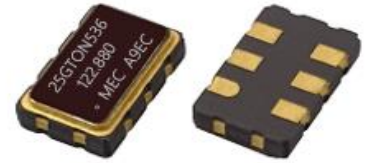

General specifications , at Ta=+25°C , CL=15pF

Model	GTQN							
Available Frequency Range	50 ~ 250 MHz							
Supply Voltage V _{DD} (code)	+ 2.5V ± 5 % (voltage code ' 25 ')				+ 3.3V ± 5 % (voltage code ' 33 ')			
Current with Output Disable	16 mA (typ.)							
Current Consumption (V _{DD} = + 2.5 V)	100 MHz : 22 mA (typ.) 32 mA (max.) ; 150 MHz : 24 mA (typ.) 34 mA (max.) ; 245 MHz : 31 mA (typ.) 41 mA (max.)							
Current Consumption (V _{DD} = + 3.3 V)	100 MHz : 24 mA (typ.) 34 mA (max.) ; 150 MHz : 28 mA (typ.) 38 mA (max.) ; 245 MHz : 37 mA (typ.) 47 mA (max.)							
Frequency Stability Codes	Frequency Stability	± 25 ppm	± 50 ppm	± 100 ppm	If non-standard please enter the desired stability after the " C " or " I " represents . For example : " C20 " ± 20 ppm over -10°C to +70°C ; " I20 " ± 20 ppm over -40°C to +85°C			
	Over Operating Temperature Range							
	Commercial (-10°C to +70°C)	A	B	C				
	Industrial (-40°C to +85°C)	D	E	F				
Output Logic " High " , " 1 "	90 % V _{DD}							
Output Logic " Low " , " 0 "	10 % V _{DD}							
Rise Time / Fall Time	10.0 nsec. (max.) [10% ↔ 90% waveform]							
Start-up Time	10.0 msec. (max.)							
Output Load	15 pF							
Duty Cycle	50 % ± 5%							
Aging at Ta = +25°C	± 5 ppm (max.) for first year							
Storage Temperature	-55°C to + 150°C							
RMS Jitter [12 kHz ~ 20 MHz]	0.6 psec (typ.)							
Phase Noise [dBc / Hz (typ.)]	Offset	10 Hz	100 Hz	1 KHz	10 KHz	100 KHz	1 MHz	10 MHz
	125 MHz	-69	-97	-114	-124	-129	-136	-154
	212.5 MHz	-53	-86	-109	-118	-121	-133	-151
Control Voltage Function on Pad 1								
Supply Voltage	V _{DD} = +2.5 V ; Vcon Center = +1.25V				V _{DD} = +3.3 V ; Vcon Center = +1.65V			
Vcontrol Range	+ 0.2V ~ +2.3V				+ 0.3V ~ +3.0V			
Frequency Pulling Range	± 80 ppm (min.)				± 80 ppm (min.)			
	Up to ± 200 ppm (min.) is also available. Please contact Mercury.							
Linearity	± 5% (typ.) ±10% (max.)							
Transfer Function	Positive Transfer							
Input Impedance	1 MΩ (typ.)							
Bandwidth	10 KHz (min.) Measured at -3 dB							
Output Enable Function on Pad 2								
OE Control on Pad 2	70% of V _{DD} (min.) to enable output. (Open connection prohibit)							
	30% of V _{DD} (max.) to disable output.							
Output Enable Time / Disable Time	200 nsec. (max.) / 50 nsec.(max.)							

GPQN _ _

PECL
Differential

0.6 ps
RMS Jitter

SMD

2.5 V

3.3 V

Min.
10 MHz

Max.
1,500 MHz

Features

Mercury's Low Jitter Differential VCXO, with low current consumption (54 mA for LVPECL 622.080 MHz at 3.3V) & an integrated phase jitter performance of 0.6 ps RMS. Gaining its precision frequency control market position by providing engineers with few-day samples for prototypes and low cost, fast delivery for volume production. The perfect solution to replace traditional XO's & VCXO's that use a more expensive, high frequency, fundamental crystal and a noisy PLL multiplier circuit.

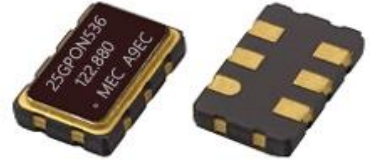

General specifications , at Ta=+25°C

Model	GPQN							
Available Frequency Range	10 ~ 1,500 MHz							
Supply Voltage V _{DD} (code)	+ 2.5V ± 5 % (voltage code ' 25 ')				+ 3.3 V ± 5 % (voltage code ' 33 ')			
Current with Output Disable	16 mA (typ.)							
Current Consumption (V _{DD} = + 2.5 V)	250 MHz : 48 mA (typ.) 58 mA (max.) ; 750 MHz : 56 mA (typ.) 66 mA (max.) ; 1,350 MHz : 65 mA (typ.) 75 mA (max.)							
Current Consumption (V _{DD} = + 3.3 V)	250 MHz : 55 mA (typ.) 65 mA (max.) ; 750 MHz : 64 mA (typ.) 74 mA (max.) ; 1,350 MHz : 72 mA (typ.) 82 mA (max.)							
Frequency Stability Codes	Frequency Stability Over Operating Temperature Range	± 25 ppm	± 50 ppm	± 100 ppm	If non-standard , please enter the desired stability after the " C " or " I " represents . For example : " C20 " ± 20 ppm over -10°C to +70°C ; " I20 " ± 20 ppm over -40°C to +85°C			
	Commercial (-10°C to +70°C)	A	B	C				
	Industrial (-40°C to +85°C)	D	E	F				
Output Logic " High " , " 1 "	V _{DD} - 1.03 (min.) , V _{DD} - 0.6 (max.)							
Output Logic " Low " , " 0 "	V _{DD} - 1.85 (min.) , V _{DD} - 1.6 (max.)							
Rise Time / Fall Time	0.5 nses. (max.) [20% ↔ 80% waveform]							
Start-up Time	10.0 msec. (max.)							
Output Load	RL = 50 Ω to (V _{DD} -2.0V). See test circuit below.							
Duty Cycle	50 % ± 5%							
Aging at Ta = +25°C	± 5 ppm (max.) for first year							
Storage Temperature	-55°C to + 150°C							
RMS Jitter [12 kHz ~ 20 MHz]	0.6 psec (typ.)							
Phase Noise [dBc / Hz (typ.)]	Offset	10 Hz	100 Hz	1 KHz	10 KHz	100 KHz	1 MHz	10 MHz
	125 MHz	-69	-97	-114	-124	-129	-136	-154
	212.5 MHz	-53	-86	-109	-118	-121	-133	-151
Control Voltage Function on Pad 1								
Supply Voltage	V _{DD} = +2.5 V ; Vcon Center = +1.25V				V _{DD} = +3.3 V ; Vcon Center = +1.65V			
Vcontrol Range	+ 0.2V ~ +2.3V				+ 0.3V ~ +3.0V			
Frequency Pulling Range	± 80 ppm (min.)				± 80 ppm (min.)			
	Up to ± 200 ppm (min.) is also available. Please contact Mercury.							
Linearity	± 5% (typ.) ±10% (max.)							
Transfer Function	Positive Transfer							
Input Impedance	1 MΩ (typ.)							
Bandwidth	10 KHz (min.) Measured at -3 dB							
Output Enable Function on Pad 2								
OE Control on Pad 2	70% of V _{DD} (min.) to enable output. (Open connection prohibit)							
	30% of V _{DD} (max.) to disable output.							
Output Enable Time / Disable Time	200 nsec. (max.) / 50 nsec. (max.)							

GDQN _ _

LVDS
Differential

0.6 ps
RMS Jitter

SMD

2.5 V

3.3 V

Min.
10 MHz

Max.
1,500 MHz

Features

Mercury's Low Jitter Differential VCXO, with low current consumption (22 mA for LVDS 622.080 MHz at 3.3V) & an integrated phase jitter performance of 0.6ps RMS. Gaining its precision frequency control market position by providing engineers with few days samples for prototypes and low cost, fast delivery for volume production. The perfect solution to replace traditional XO's & VCXO's that use a more expensive highfrequency, fundamental crystal and a noisy PLL multiplier circuit.

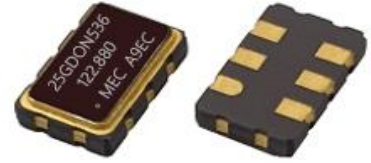

General specifications , at Ta=+25°C

Model	GDQN							
Available Frequency Range	10 ~ 1,500 MHz							
Supply Voltage V _{DD} (code)	+ 2.5V ± 5 % (voltage code ' 25 ')				+ 3.3 V ± 5 % (voltage code ' 33 ')			
Current with Output Disable	16 mA (typ.)							
Current Consumption (V _{DD} = + 2.5 V)	250 MHz : 18 mA (typ.) 28 mA (max.) ; 750 MHz : 22 mA (typ.) 32 mA (max.) ; 1,350 MHz : 26 mA (typ.) 36 mA (max.)							
Current Consumption (V _{DD} = + 3.3 V)	250 MHz : 30 mA (typ.) 40 mA (max.) ; 750 MHz : 39 mA (typ.) 49 mA (max.) ; 1,350 MHz : 47 mA (typ.) 57 mA (max.)							
Frequency Stability Codes	Frequency Stability	± 25 ppm	± 50 ppm	± 100 ppm	If non-standard , please enter the desired stability after the " C " or " I " represents . For example : " C20 " ± 20 ppm over -10°C to +70°C ; " I20 " ± 20 ppm over -40°C to +85°C			
	Over Operating Temperature Range							
	Commercial (-10°C to +70°C)	A	B	C				
	Industrial (-40°C to +85°C)	D	E	F				
Output Logic " High " , " 1 "	1.4 V (typ.) ; 1.6 V (max.)							
Output Logic " Low " , " 0 "	0.9 V (min.) ; 1.1 V (typ.)							
Rise Time / Fall Time	0.4 nsec. (max.) [20% ↔ 80% waveform]							
Start-up Time	10.0 msec. (max.)							
Output Load	100 Ω between output and complimentary output							
Duty Cycle	50 % ± 5%							
Aging at Ta = +25°C	± 5 ppm (max.) for first year							
Storage Temperature	-55°C to + 150°C							
RMS Jitter [12 kHz ~ 20 MHz]	0.6 psec (typ.)							
Phase Noise [dBc / Hz (typ.)]	Offset	10 Hz	100 Hz	1 KHz	10 KHz	100 KHz	1 MHz	10 MHz
	125 MHz	-69	-97	-114	-124	-129	-136	-154
	212.5 MHz	-53	-86	-109	-118	-121	-133	-151
Control Voltage Function on Pad 1								
Supply Voltage	V _{DD} = +2.5 V ; V _{con} Center = +1.25V				V _{DD} = +3.3 V ; V _{con} Center = +1.65V			
V _{control} Range	+ 0.2V ~ +2.3V				+ 0.3V ~ +3.0V			
Frequency Pulling Range	± 80 ppm (min.)				± 80 ppm (min.)			
	Up to ± 200 ppm (min.) is also available. Please contact Mercury.							
Linearity	± 5% (typ.) ±10% (max.)							
Transfer Function	Positive Transfer							
Input Impedance	1 M Ω (typ.)							
Bandwidth	10 KHz (min.) Measured at -3 dB							
Output Enable Function on Pad 2								
OE Control on Pad 2	70% of V _{DD} (min.) to enable output. (Open connection prohibit)							
	30% of V _{DD} (max.) to disable output.							
Output Enable Time / Disable Time	200 nsec. (max.) / 50 nsec.(max.)							

Voltage Controlled Crystal Oscillators [VCXO]

GTQN

GPQN

GDQN

Q family

N series

SMD

2.5 V

3.3 V

Part Number Format and Example

Example : 3GPQN576 - E - 100N - 622.080

3	GPQN	576	-	E	-	100N	-	622.080
Supply Voltage " 3 " for 3.3V " 25 " for 2.5V	GTQN : CMOS GPQN : PECL GDQN : LVDS	Package Size " 576 " : 7.0*5.0 mm " 536 " : 5.0*3.2 mm " 326 " : 3.2*2.5 mm		Frequency Stability Code " E " : ± 50 ppm over -40 to +85°C Other frequency stabilities are available.		±100 ppm (min.) frequency pulling range		Frequency (MHz)

Outline Dimensions (Unit : mm) , Suggested pad Layout for SMDs

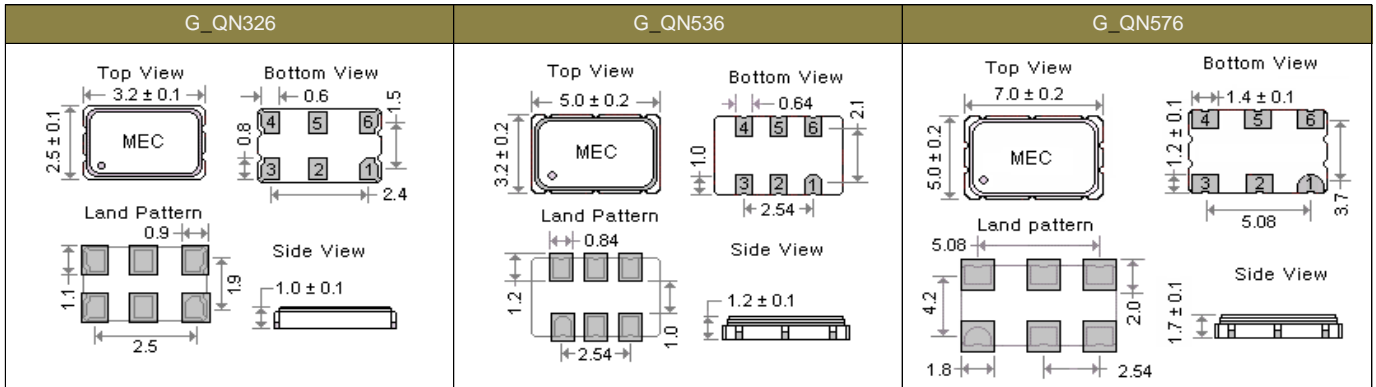

Pad Connections :

Pad 1 : VCXO ; **Pad 2 :** OE: High Enable ; **Pad 3 :** Ground

Pad 4 : [CMOS : Output , PECL or LVDS : Differential] ; **Pad 5 :** [CMOS : NC , PECL or LVDS : Complementary] ; **Pad 6 :** Supply Voltage

Test Circuits and Output Waveforms

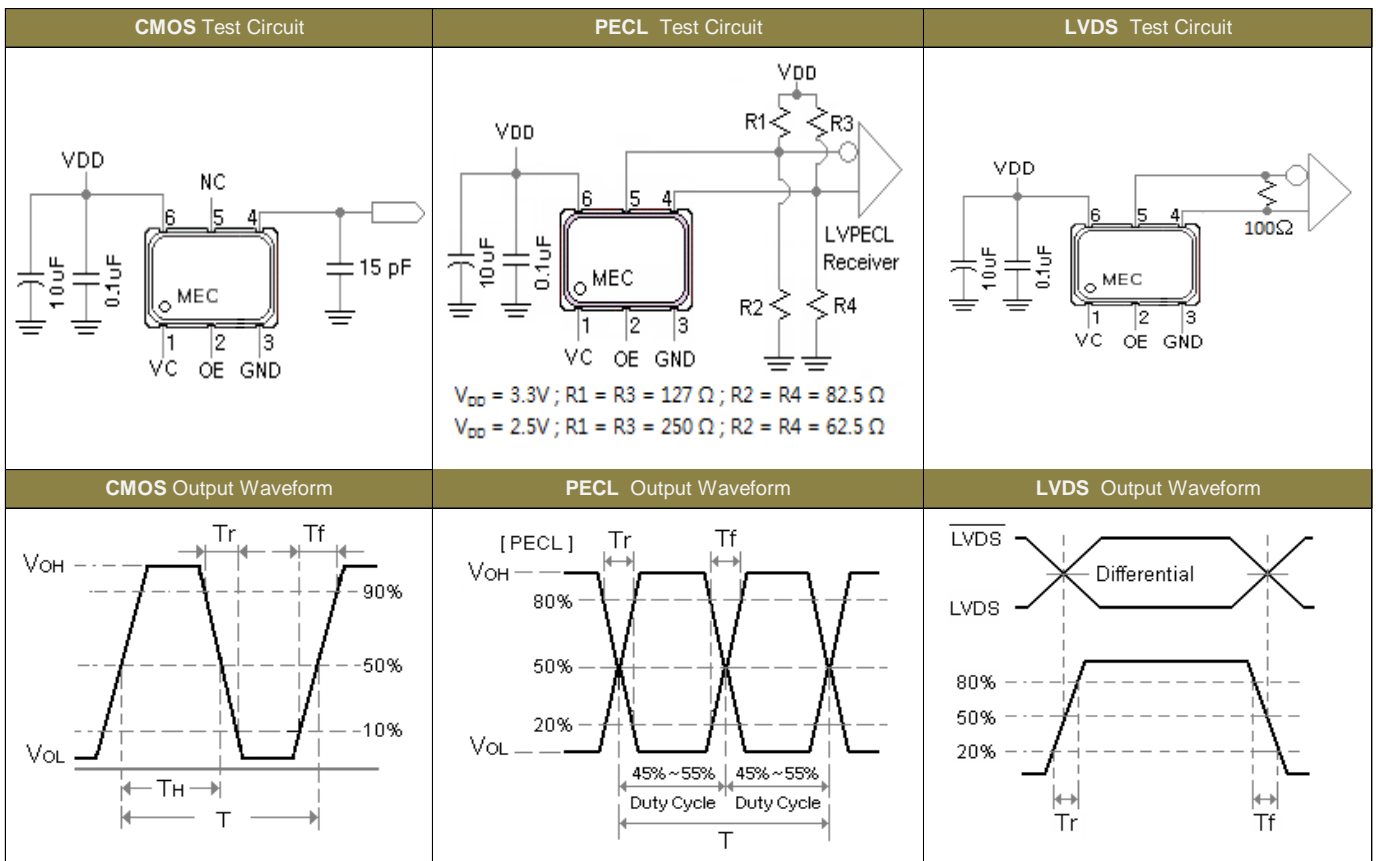

Mercury www.mercury-crystal.com ■ Taiwan : Tel: (+886)-2-2406-2779 / sales-tw@mercury-crystal.com

■ USA : Tel: (+1)-909-466-0427 / sales-us@mercury-crystal.com ■ China : Tel: (+86)-512-5763-8100 / sales-cn@mercury-crystal.com

Emboss Taping and Reel Specifications

[VCXO]

[(VC)TCXO]

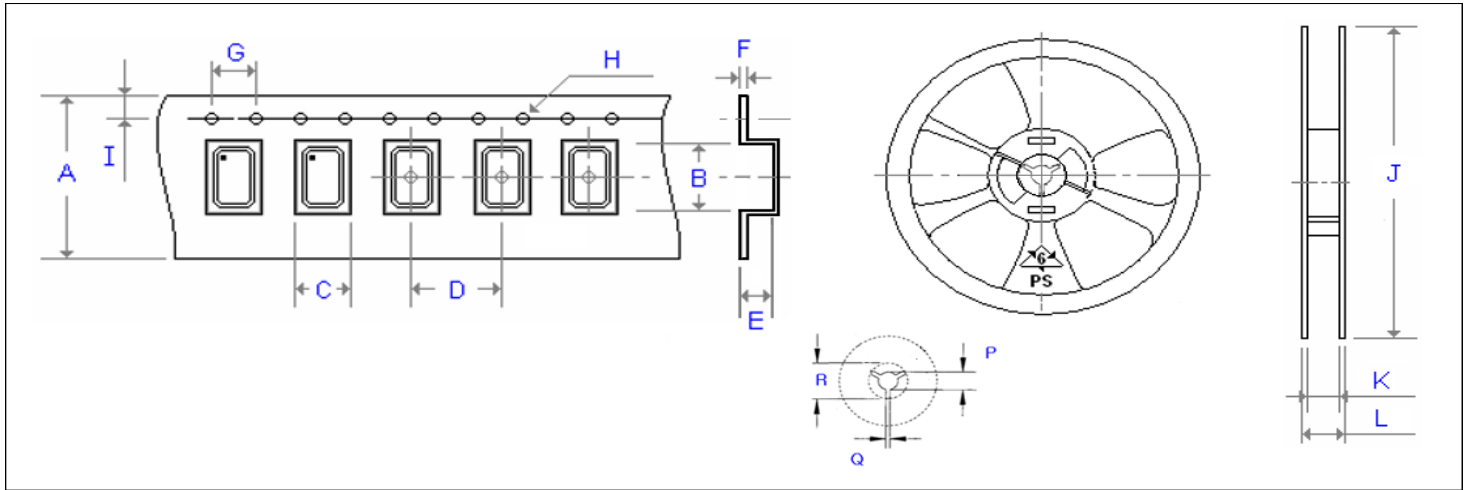

Carrier Type Dimensions (unit : mm) ±0.3mm

	A	B	C	D	E	F	G	H	I	pcs / reel
G_226	8.00	2.80	2.25	4.00	1.10	0.30	4.00	∅ 1.50	1.75	3000
G_326	8.00	3.40	2.70	4.00	1.40	0.25	4.00	∅ 1.50	1.75	3000
G_534	12.00	5.30	3.60	8.00	1.40	0.30	4.00	∅ 1.50	1.75	1000
G_576	16.00	7.30	5.30	8.00	1.90	0.32	4.00	∅ 1.50	1.75	1000
G_43	24.00	11.80	10.00	16.00	5.00	0.30	4.00	∅ 1.50	1.75	500
G_63	24.00	11.80	10.00	16.00	5.00	0.30	4.00	∅ 1.50	1.75	500
G_JF538	12.00	5.30	3.60	8.00	1.40	0.30	4.00	∅ 1.50	1.75	1000
G_JF578	16.00	7.30	5.30	8.00	1.90	0.32	4.00	∅ 1.50	1.75	1000
(V)M21	8.00	2.30	1.90	4.00	0.90	0.25	4.00	∅ 1.50	1.75	3000
(V)ME21	8.00	2.30	1.50	4.00	1.35	0.25	4.00	∅ 1.50	1.75	3000
(V)M22	8.00	2.80	2.25	4.00	1.10	0.30	4.00	∅ 1.50	1.75	3000
(V)M_32	8.00	3.71	2.80	4.00	1.75	0.25	4.00	∅ 1.50	1.75	3000
(V)MQ_326	12.00	3.60	2.90	4.00	1.70	0.30	4.00	∅ 1.50	1.75	3000
(V)M_53	12.00	5.30	3.60	8.00	1.40	0.30	4.00	∅ 1.50	1.75	1000
(V)M_57(2)	16.00	7.40	5.50	8.00	2.80	0.35	4.00	∅ 1.50	1.75	500
(V)M_43 (63)	24.00	11.80	10.00	16.00	5.00	0.30	4.00	∅ 1.50	1.75	500

Reel Dimensions (unit : mm) ±2mm

	J	K	L	P	Q	R	pcs / reel
G_226	180.00	8.40	11.40	13.00	2.50	20.20	3000
G_326	180.00	9.00	12.00	13.00	2.50	20.20	3000
G_534	180.00	13.00	16.00	13.00	2.50	20.20	1000
G_576	180.00	17.20	19.30	13.00	2.50	20.20	1000
G_43	330.00	24.50	29.10	13.00	2.50	20.20	500
G_63	330.00	24.50	29.10	13.00	2.50	20.20	500
G_JF538	180.00	13.00	16.00	13.00	2.50	20.20	1000
G_JF578	180.00	17.20	19.30	13.00	2.50	20.20	1000
(V)M21	180.00	8.40	11.40	13.00	2.50	20.20	3000
(V)ME21	180.00	9.00	12.00	13.00	2.50	20.20	3000
(V)M22	180.00	8.40	11.40	13.00	2.50	20.20	3000
(V)M_32	180.00	9.00	11.40	13.00	2.50	20.20	3000
(V)MQ_326	180.00	13.00	16.00	13.00	2.50	20.20	3000
(V)M_53	180.00	13.00	16.00	13.00	2.50	20.20	1000
(V)M_57(2)	180.00	17.20	19.30	13.00	2.50	20.20	500
(V)M_43 (63)	330.00	24.50	29.10	13.00	2.50	20.20	500

Mercury www.mercury-crystal.com ■Taiwan : Tel: (+886)-2-2406-2779 / sales-tw@mercury-crystal.com

■USA : Tel: (+1)-909-466-0427 / sales-us@mercury-crystal.com ■China : Tel: (+86)-512-5763-8100 / sales-cn@mercury-crystal.com